

Wickleinrichtung

Winding System

Wickleinrichtung  
 obere Spule  
 mech.

Winding System  
 upper spool  
 mech.

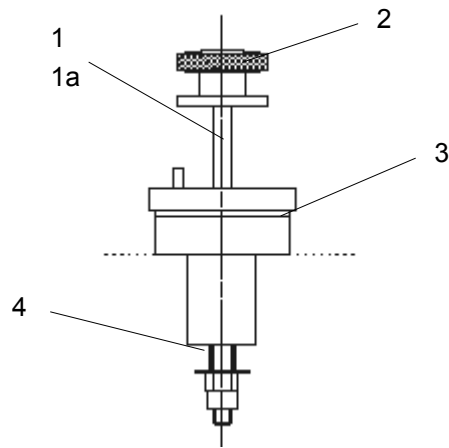

Wickleinrichtung  
 untere Spule  
 elektr.

Winding System  
 lower spool  
 electr.

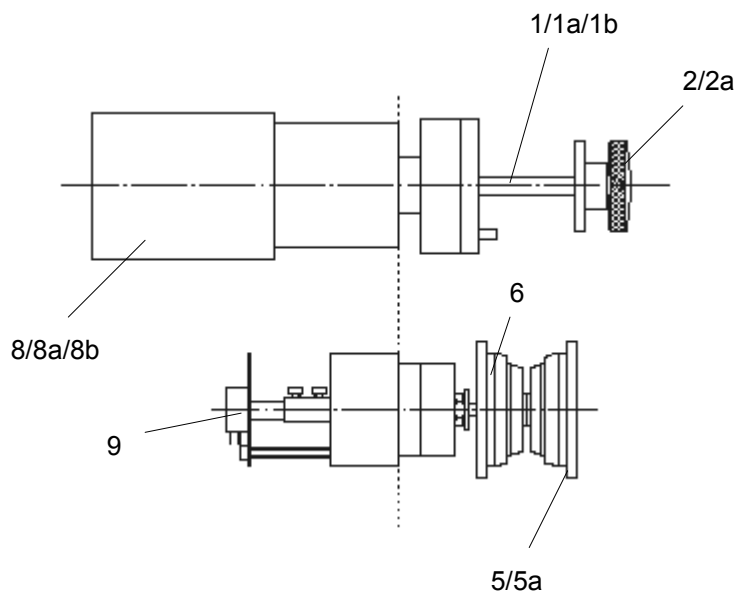

Wickeleinrichtung

Winding System

POS.	ARTIKEL-No.	BEZEICHNUNG	DESCRIPTION	QUANTITY
1	1 530 279	Achse 8mm, 4-kt	Axle 8mm square	2
1a	3 530 203	Achse 9,2mm	Axle 9,2mm	2
1b	3 530 248	Achse 12,7mm	Axle 12,7mm	2
2	3 630 142	Griff 9,2mm	Holder 9,2mm	2
2a	3 630 143	Griff 12,7mm	Holder 12,7mm	2
3	1 530 099	Friktionsscheibe	Friction disk	1
4	1 650 013	Druckfeder	Spring friction	1
5	1 536 510	Halbschale 2000m	Half roller 2000m	2
5a	3 530 023	Halbschale 5000m	Half roller 5000m	2
6	1 620 075	Sicherungsscheibe	Washer	2
7	3 534 288	Stützrolle	Smal roller	1
8	2 014 426	Motor 2000m	Motor 2000m	1
8a	2 014 425	Motor 3200m	Motor 3200m	2
8b	2 014 424	Motor 5000m	Motor 5000m	2
9	1 770 224	Potentiometer	Potentiometer	2